



Rebate Program Refresher and Update – Heat Pumps

Lower Mainland & Vancouver Island

Housekeeping

- Attendees are muted and videos off
- Use Q&A box for questions
 - Opportunity to raise your hand and be unmuted during Q&A later
- Use chat box for comments/other discussions
- Will be recorded and slides will be sent out

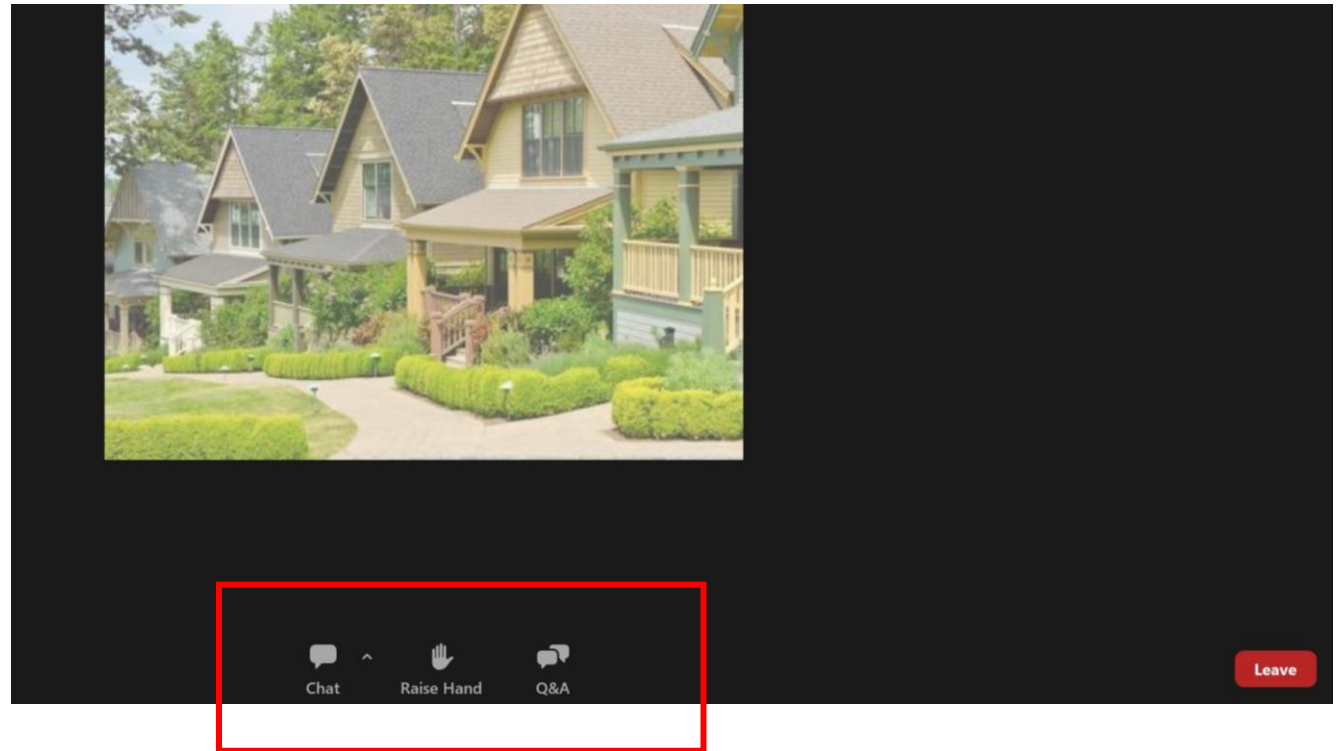

Agenda

- The HPSC and Rebate Programs
- Rebate Program Refresher and Update
 - Introductions
 - Year in review
 - Helping your customers
- Q&A
- Contact Information

The HPSC and Rebate Programs

The HPSC & Rebate Programs



HOME PERFORMANCE CONTRACTOR NETWORK

Contractor Quality Assurance







REBATE & INCENTIVE PROGRAMS

Program Administration and Project Verification



The HPSC & Rebate Programs

Program Administrator	Program Name	Rebate Type
	CleanBC Better Homes Income-Qualified Offer	<ul style="list-style-type: none"> • Windows & doors • Heat pumps • Insulation
	CleanBC Better Homes	<ul style="list-style-type: none"> • Heat pumps • Insulation
	Home Renovation Rebate Program	<ul style="list-style-type: none"> • Heat pumps • Insulation
	Home Renovation Rebate Program <i>and</i> FortisBC Income Qualified Rebate Program	<ul style="list-style-type: none"> • Heat pumps • Insulation
	Home Heating System Tune Up and Smart Thermostat Program	<ul style="list-style-type: none"> • Furnace or boiler tune-ups • Smart thermostat installations

Rebate Program Refresher and Update

Rebate Program Training for Heat Pumps

June 2023

We're working together to help B.C. save energy



Introductions

BC Hydro

- Anthony Ceh
- Kirsty Pappas
- Luis Damy

FortisBC

- Erica Gugay
- Tammy Grant

Government of BC

- Grant Moonie

We're working together to help B.C. save energy



Agenda

1. Year in review

2. Helping your customers

1. Understand the rebates available and program requirements
2. Must be a Home Performance Contractor Network member
3. Know where customers can find you on our approved listings
4. Install to best practice standards
5. Include important info on invoices

3. Questions

We're working together to help B.C. save energy



Year in review

Total # of heat pump applications paid out in the past year

Nov 2021 to Nov 2022	BC Hydro Service Territory	FortisBC Electric Service Territory
Electric to heat pump	5,228	399
Fossil fuel to heat pump	4,763	83
Total	9,991	482
	10,473	
Vancouver Island*	63%	
Lower Mainland	31%	
Central	5%	
North	1%	

*BC Hydro has been offering heat pump rebates since 2015, large population of electrically heated homes are on Vancouver Island, and as a result high participation in this region

We're working together to help B.C. save energy



Helping your customers

1. Understand the rebates available and program requirements
2. Must be a Home Performance Contractor Network member
3. Know where customers can find you on our approved listings
4. Install to best practice standards
5. Include important info on invoices

We're working together to help B.C. save energy



Heat Pump Rebates in BC

Provincial

Up to \$6,000



Federal

Up to \$5,600

Canada Greener Homes Grant

Start your energy-efficient retrofits
Apply and get advice on making your home more energy-efficient.

Explore careers in energy efficiency
Get trained to be an energy advisor or register as an eligible service organization.

Discover energy efficiency resources
Retrofit your home with the know-how to get it done right.

The graphic features a large green arrow pointing upwards, overlaid on a photograph of a woman sitting on a couch, holding a smartphone and a mug. Below the arrow are three small inset images: a person working on a wall, two people talking, and a person looking at a laptop.

We're working together to help B.C. save energy



Better Homes and Home Renovation Rebate Program Overview

- Integrated offer of financial rebates for residential customers looking to make energy efficient upgrades to their homes
- Partners:
 - Province of B.C.
 - BC Hydro
 - FortisBC
- Goal: accelerate retrofits that help households reduce greenhouse gas emissions (GHGs) and energy use
 - High efficiency heating equipment
 - Building envelope improvements

We're working together to help B.C. save energy



General Eligibility Requirements

- FortisBC or BC Hydro residential customer (or participating municipality)
- Have electricity, natural gas, oil, wood or propane as primary heating
- Homes must be 12 months or older
- Live in an eligible home:
 - Single family detached dwelling
 - Including legal individually metered secondary suites
 - Mobile home on permanent foundation
 - Row / townhouse, duplex

We're working together to help B.C. save energy



General Eligibility Requirements

- Heat pump must replace existing primary system and serve main living space
- Be listed as a qualified system on the Qualified Heat Pump Product List (QPL)
- Must be installed by a Home Performance Contractor Network member.

We're working together to help B.C. save energy



General Eligibility Requirements

If you are switching from electrical heating to heat pump:

- Must meet minimum electricity consumption
- Calculator available at bchydro.com/homerebates

We're working together to help B.C. save energy



General Eligibility Requirements

If you are replacing a fossil fuel (oil, propane or natural gas) heating system:

- The fossil fuel heating system must be removed, and proof must be provided with invoice.
- Following documents will be accepted:
 - Local government permit or inspection report, which must include date of inspection and address where inspection took place.
 - Invoice from the removal company or heat pump contractor, which must include description of work completed and date of removal.

We're working together to help B.C. save energy



General Eligibility Requirements

If you are replacing a natural gas or propane furnace with dual fuel heat pump:

- System must have an AHRI certified reference number that references all components of the heat pump including the outdoor unit, indoor unit and the furnace.
- A heat load calculation is required and must be submitted with the application.
- Boilers are not eligible for a dual fuel ducted central heat pump rebate.

We're working together to help B.C. save energy



General Eligibility Requirements

If you are replacing a wood or solid fuel heating system:

- The existing wood or solid fuel heating system may be retained in safe and working order or removed in accordance with all applicable laws. If the customer is keeping the wood or solid fuel heating system, they must submit a copy of an WETT Inspection

We're working together to help B.C. save energy



Fossil Fuel to Heat Pump

Heat Pump Eligibility Measures and Rebates

Upgrade Category	Upgrade Type	Equipment requirements	Rebate Value
Switch from natural gas, propane or oil to an electric heat pump (BC Hydro electric service territory)	Ductless Mini-Split Heat Pump	<ul style="list-style-type: none"> Variable Speed HSPF \geq 10, SEER \geq 16 Minimum capacity of 12,000 BTU (1 ton) Eligible homes must be 1,200 sq. ft. or less 	\$6,000
	Ductless Multi-Split Heat Pump	<ul style="list-style-type: none"> Variable Speed HSPF \geq 10, SEER \geq 16 Minimum capacity of 12,000 BTU (1 ton) 	\$6,000
	Central Ducted Heat Pump	<ul style="list-style-type: none"> Variable Speed HSPF \geq 10, SEER \geq 16 Minimum capacity of 12,000 BTU (1 ton) 	\$6,000
	Dual Fuel Ducted Heat Pump	<ul style="list-style-type: none"> HSPF \geq 10, SEER \geq 16 Minimum capacity of 12,000 BTU (1 ton) 	\$3,000

Electric & Wood to Heat Pump

Heat Pump Eligibility Measures and Rebates

Upgrade Category	Upgrade Type	Equipment requirements	Rebate Value
Switch from electric resistance or wood to all-electric heat pump (BC Hydro electric service territory)	Ductless Mini-Split Heat Pump	<ul style="list-style-type: none"> Variable Speed HSPF \geq 10, SEER \geq 16 Minimum capacity of 12,000 BTU (1 ton) Eligible homes must be 1,200 sq. ft. or less 	\$1,000
	Ductless Multi-Split Heat Pump	<ul style="list-style-type: none"> Variable Speed HSPF \geq 10, SEER \geq 16 Minimum capacity of 12,000 BTU (1 ton) 	\$1,000
	Central Ducted Heat Pump	<ul style="list-style-type: none"> Variable Speed HSPF \geq 10, SEER \geq 16 Minimum capacity of 12,000 BTU (1 ton) 	\$2,000

We're working together to help B.C. save energy



Better Homes and Home Renovation Rebate Program Heat Pump QPL Upgrade

- Heat pumps manufactured after January 1, 2023 are required to be tested to the new M1 (HSPF2 and SEER2) energy efficiency test standards for products imported and sold in Canada.
- The new testing procedures for HSPF2 and SEER2 will better represent conditions seen in the field in Canada.
- Heat pumps manufactured and tested to the original HSPF and SEER standard, can continue to be sold in Canada.
- The Better Homes and Home Renovation Rebate Program efficiency requirements will accept products tested under both testing standards (HSPF/SEER and HSPF2/SEER2), effective January 1, 2023.
- If a heat pump meets the M or M1 requirement, but not both, it can be added to the Qualified Product List and will be eligible for a rebate.

We're working together to help B.C. save energy



Better Homes and Home Renovation Rebate Program Heat Pump QPL Upgrade

The program requirements for HSPF and SEER for both testing standards are provided below:

Minimum Program Requirements	
If product is tested under HSPF/SEER standard	If product is tested under new HSPF2/SEER2 standard
HSPF \geq 10.00	HSPF2 \geq 8.5
SEER \geq 16.00	SEER2 \geq 15.2

We're working together to help B.C. save energy



Greener Homes Heat Pump QPL Updates

- The Canada Greener Homes Program will be referencing the heating efficiency of heat pumps for Region V HSPF2 and SEER2 for all products being added to their Qualified Product List as of June 1, 2023
- Revised eligibility criteria for Greener Homes will specify HSPF2 and SEER2 for Region V; Region V values are lower than Region IV values.
- Program requirements for heat pumps being added to the Greener Homes Qualified Product List for non-cold climate heat pumps:
 - HSPF2 $V \geq 6.6$
 - SEER2 $V \geq 15.2$ (new requirement)
 - Addition requirements for cold climate heat pumps exist
- HSPF2 $V \geq 6.6$ does not translate directly to the provincial program requirement of HSPF2 IV ≥ 8.5
- The two programs have different program requirements and QPL's, contractors and distributors will need to ensure heat pumps are on the QPL's of each program.
- More details will be distributed on the change.

We're working together to help B.C. save energy



CleanBC Income Qualified Program

Program Overview

- The CleanBC Better Homes Income Qualified Program provides enhanced rebates covering up to 95% of project costs to help make energy-saving home upgrades more affordable
- Complement to existing energy efficiency rebate programs offered in British Columbia
- Developed and funded by the Province of British Columbia and administered in partnership with CLEAResult Canada

We're working together to help B.C. save energy



CleanBC Income Qualified Program

Program Goals

- **Improve Energy Affordability**
 - Enable income-qualified households facing financial hardship to achieve higher efficiencies
- **Increase Market Awareness**
 - Enrich residents' knowledge of energy efficiency and fuel switching opportunities
- **Reduce Greenhouse Gas Emissions**
 - Support achieving GHG emission reductions to address climate change

We're working together to help B.C. save energy



CleanBC Income Qualified Program

Eligibility Requirements

MAXIMUM INCENTIVES

Level 1

Incentive capped at **95%** of project costs, up to a maximum per measure

Level 2

Incentive capped at **60%** of project costs, up to a maximum per measure

ELIGIBLE HOUSING TYPES



Single family detached home



Duplex



Row/Townhouse



Manufactured/
Mobile home*



Secondary suite in a single family detached home**

*Must be on a permanent foundation

**Must have an independent utility meter

ELIGIBLE MEASURES



Windows/Doors

Up to **\$9,500**, \$950 per window or door



Insulation

Up to **\$5,500**



Heat Pumps

Up to **\$9,500**



Heat Pump Water Heaters

Up to **\$3,500**

Additional rebates available for ventilation, health & safety, and electrical panel upgrades.

All participants must pay for their own utility bills.

Additional terms and conditions apply, visit betterhomesbc.ca/income-qualified for more details.

We're working together to help B.C. save energy



CleanBC Income Qualified Program

Eligibility Requirements

Participation Journey

Contractor-based retrofit program for income qualified households in B.C.

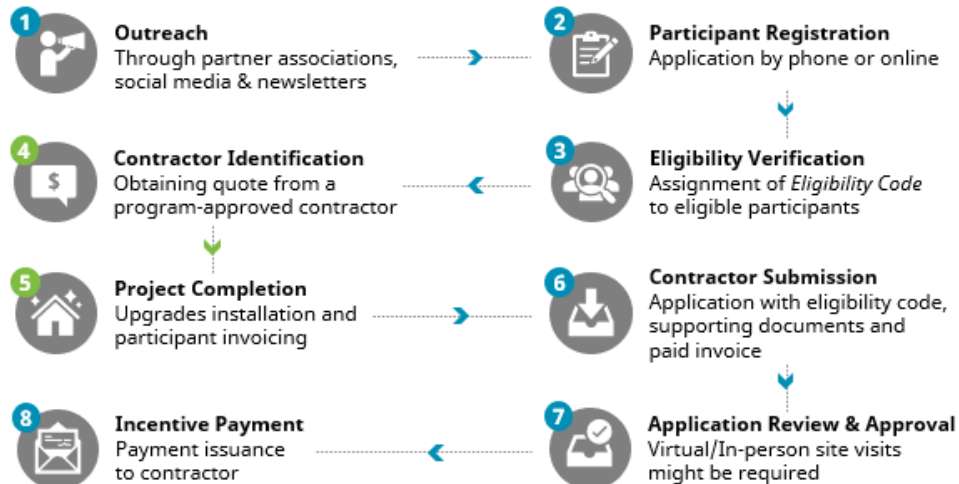

ADDITIONAL OPTIONAL SERVICES

For Participants

Energy Coaching & Assessments

- Contractors Identification
- Energy Education
- Enrollment Support
- Measure Prioritization
- Program Requirements
- Quote Review
- Understanding Invoices

For Contractors

Energy Coaching

- Application Support
- Payment Processing Support
- Program Requirements
- Verification of Eligibility Code
- Verification of Equipment Eligibility

We're working together to help B.C. save energy



CleanBC Income Qualified Program

- Ductless mini- and multi-split, central ducted and dual fuel ducted heat pump rebates are available.
- Homes converting from natural gas, propane or oil – 60% - 95% of eligible upgrade costs, up to a maximum of **\$9,500 per home**
- Homes converting from electricity or wood – 60% - 95% of eligible upgrade costs, up to a maximum of **\$5,000 per home**
- Income Qualified Program details available at <https://betterhomesbc.ca/rebates/income-qualified/>
- Become an Income Qualified Program Registered Contractor by contacting IQPcontractorsupport@clearesult.com

We're working together to help B.C. save energy



Heat Pump Rebates in BC

Program Differences

Important:

- Separate rebate processes – Greener Homes administered by Government of Canada
- Rebate requirements must be met for each program independently
- Stacking rebates cannot exceed the total cost of the installation

	Pre-registration	EnerGuide assessment	Stackable	Licensed contractor	HPCN Member
Provincial Rebate Programs: Better Homes and Home Renovation Rebate	No	No	Yes, with GH only	Yes	Yes
CleanBC Income Qualified Program	Yes	No	Yes, with GH only	Yes	Yes
Federal rebate program: Greener Homes Grant (GH)	Yes	Yes	Yes	Yes	No

We're working together to help B.C. save energy



Helping your customers

1. Understand the rebates available and program requirements
2. **Must be a Home Performance Contractor Network member**
3. Know where customers can find you on our approved listings
4. Install to best practice standards
5. Include important info on invoices

We're working together to help B.C. save energy



Home Performance Contractor Network

- Customers must use a contractor who is listed on the Home Performance Contractor Network directory in order to be eligible for provincial heat pump rebates
- HPCN is managed by the Home Performance Stakeholder Council (HPSC)
- Training and wage subsidies available for limited time.
- Visit <http://homeperformance.ca/about-the-network/> for more information
- If you have completed the designation, we recommend you get more estimators and installers onboarded
 - Ensure all key employees complete the designation requirements



We're working together to help B.C. save energy



Helping your customers

1. Understand the rebates available and program requirements
2. Become a member of the Home Performance Contractor Network member
3. Know where customers can find you on our approved listings
4. Install to best practice standards
5. Include important info on invoices

We're working together to help B.C. save energy



Contractor Directory

- betterhomesbc.ca/find-a-contractor
- bchydro.com/hpcn
- homeperformance.ca/find-a-contractor



Rebate Search Tool

About Us

Contact Us



Find a registered contractor near you

What **type** of efficiency upgrade are you planning?

All Types



Where is the home **located**?

Enter municipality or regional district

Submit

We're working together to help B.C. save energy



Helping your customers

1. Understand the rebates available and program requirements
2. Must be a Home Performance Contractor Network member
3. Know where customers can find you on our approved listings
4. **Install to best practice standards**
5. Include important info on invoices

We're working together to help B.C. save energy



Installation Best Practice

- Program requirement that heat pumps are being installed following the best practice guide – developed in partnership by industry experts
- Applications may be sent to site visit before the rebate is processed
 - Collecting information regarding the products installed
 - Checking installation practices
 - Taking photos of the upgrade
- Best practice guide can be found at bchydro.com/contractors



We're working together to help B.C. save energy



Installation Best Practice

Example 1: Line set insulation



POOR INSTALLATION

BEST PRACTICE INSTALLATION



Line Set and Penetrations



Line set not properly insulated

Source: Best Practices Installation Webinar, NEEA



Line set properly insulated

Source: Best Practices Installation Webinar, NEEA

We're working together to help B.C. save energy



Installation Best Practice

Example #2: Secure outdoor unit

Exhibit 25: Outdoor Unit on Concrete Pad

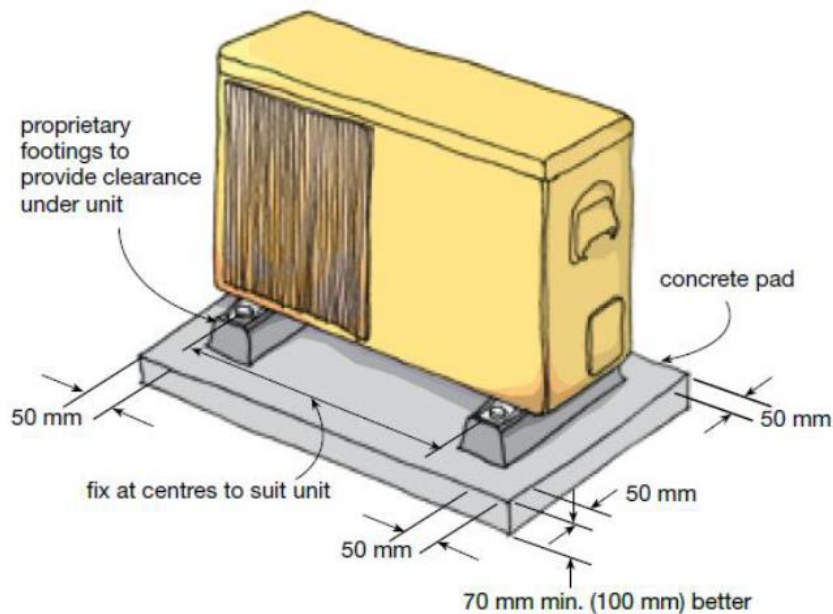
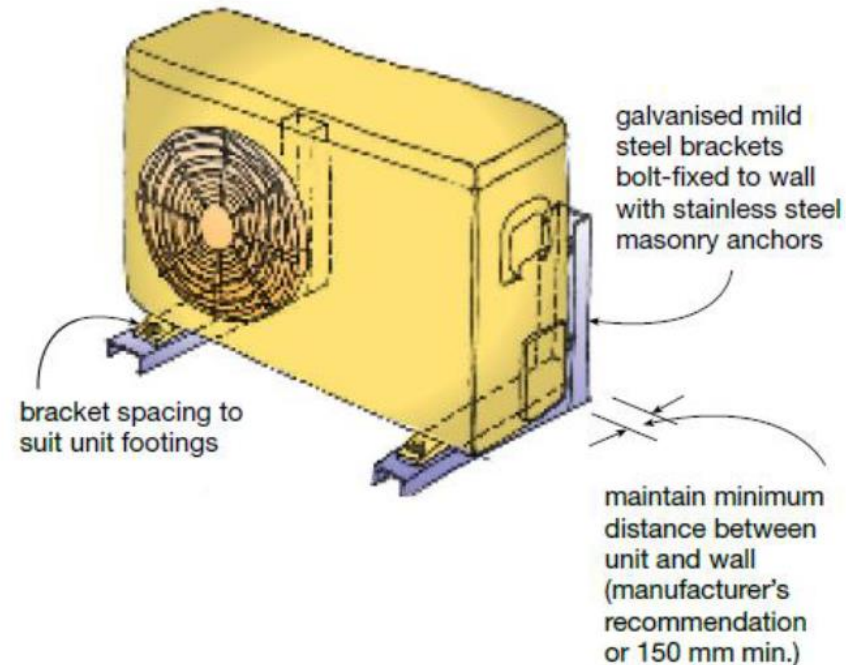

Exhibit 26: Wall Mounted Outdoor Unit on Bracket - Masonry Wall



We're working together to help B.C. save energy



Installation Best Practice

Example #3 Set Points

- Balance set points for dual fuel systems
 - 5⁰C for Vancouver Island and the Lower Mainland
 - 2⁰C for the Interior and Northern Regions



We're working together to help B.C. save energy



Helping your customers

1. Understand the rebates available and program requirements
2. Must be a Home Performance Contractor Network member
3. Know where customers can find you on our approved listings
4. Install to best practice standards
5. **Include important info on invoices**

We're working together to help B.C. save energy



Application Process

- Customers must:
 - Apply online within six (6) months of invoice date
 - Provide copies of all required documentation including invoices
 - Complete the application form at bchydro.com/hero
- Applications processed within 90 days
- Customers can check status online

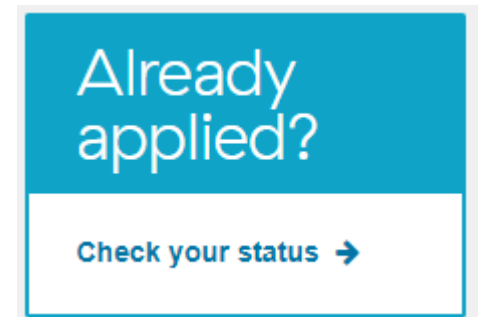
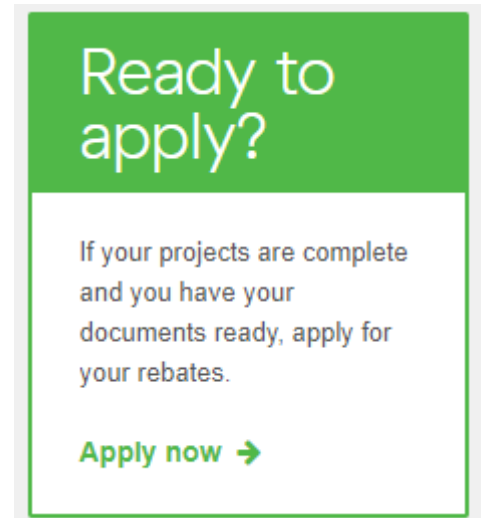

We're working together to help B.C. save energy



Invoice Requirements

- Heat pump invoices must include:
 - Make & model numbers for all components
 - AHRI number or copy of AHRI certificate
 - Capacity of the system (BTU)
 - Invoice date, customer & company information including GST number
- Providing the required details will ensure rebate applications are processed without delay

Sample Invoice



The ASHP Company
123 Main Street Vancouver, BC V2M 4L8
1 (866) 875-2736
hello@ashpc.com

PO#: 112099
GST 123456789 RT 0001

INSTALLATION ADDRESS

Mr. Joe Bewarm
4353 Ontario Street
Vancouver, BC
V2M 4L8

INVOICE DATE

15/04/2022

PLEASE PAY

\$13,440.00

DUE DATE

15/05/2022

DESCRIPTION	HRS/QTY	RATE	SUBTOTAL
Supply and installation of new SEER 16 and HSPF 9.30 central ducted heat pump: Make: WarmAir Outdoor Model: KW30-898UX-012 Indoor Model(s): KWV060UX AHRI number: 1234567 Number of tons: 2.5	1	\$11,000.00	\$11,000.00
Removal and or decommission of fossil fuel system including applicable tank(s) from customer premise on 15/04/2022.	1	\$1,800.00	\$1,800.00
			SUBTOTAL \$12,800.00
			GST (5%) \$640.00
			TOTAL \$13,440.00

PAID

We're working together to help B.C. save energy



Program Support

Contractor Portal

bchydro.com/contractors



Home > Energy savings > Residential > Rebates & free programs > Rebates for home renovations > Resources for contractors

Resources for contractors

Rebates for home renovations

- [Heat pumps](#)
- [Insulation](#)
- [Water heating](#)
- [Windows & doors](#)

Quick links

- [General program eligibility](#)
- [Electricity consumption check](#)
- [Contractor invoice requirements](#)
- [Bonus rebates available](#)

Heat pump resources

- [Rebate guide](#) (PDF, 99 KB)
- [Best Practice Installation Guide](#)
- [Eligible heat pump list](#)

Contractor directory

- [Heat Pump contractors](#)
- [Insulation contractors](#)

Insulation resources

- [Rebates & program eligibility](#)
- [Best Practice Installation Guide](#)

Rebate program training

Training is offered to contractors twice per year (spring and fall). Check back to sign up for an invitation to the next training session.

Still have questions? Contact the Alliance

alliance@bchydro.com

Program Support

Customers

- Direct customers to contact a Better Homes energy coach, available M-F, 9am to 5pm
 - Hotline: 1-844-881-9790
 - Email: ask@betterhomesbc.ca

We're working together to help B.C. save energy



Contractor Support

BC Hydro	CleanBC	FortisBC
Home Renovation Rebate alliance@bchydro.com	Better Homes betterhomes@gov.bc.ca	Home Renovation Rebate qualityinstalls@fortisbc.com
www.bchydro.com/contractors	www.betterhomesbc.ca/	www.fortisbc.com/homerebates



Questions about the HPCN:
HomePerformance.ca
info@homeperformance.ca
604-755-3469

We're working together to help B.C. save energy



Questions and Answers

- Questions
 - Type your questions or upvote other questions
 - Raise your hand and wait to be unmuted
- Comments/discussion
 - Use the chat box

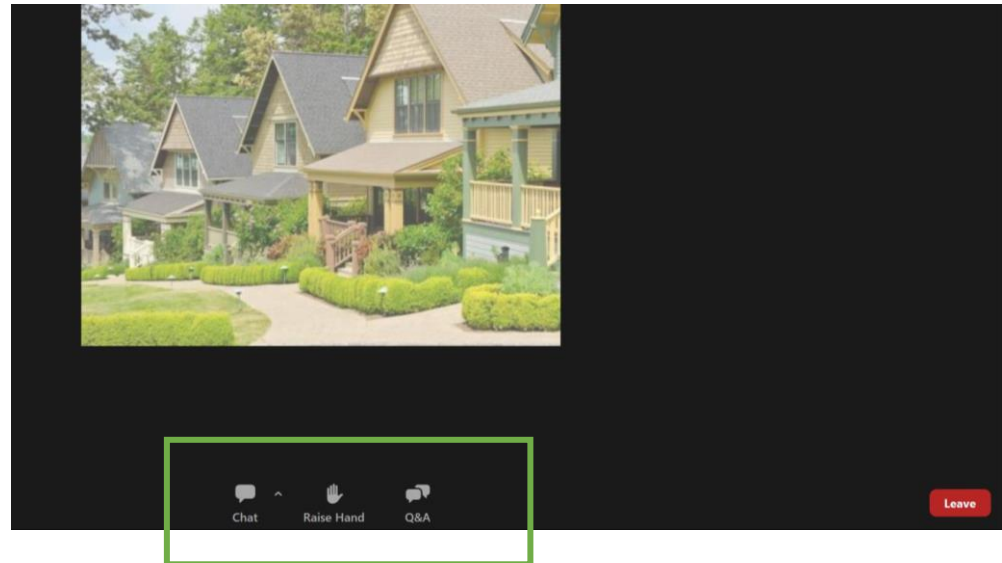

We're working together to help B.C. save energy



Thank you

We're working together to help B.C. save energy

